

# 2030G-3

3-SERIES FORK TRUCK

ENGINE  
Kubota  
(LPG)

RATED POWER  
55.4 hp  
(41.3 KW)

CAPACITY  
6,000 lb  
(3,000 kg)





# SPECIFICATIONS

EXCLUSIVELY FOR DEALER

## GENERAL

Model	CLG2030G-3		
Power type	LPG		
Operator type	1	Sit-Down Rider	
Base capacity	2	6,000 lb (3,000 kg)	
Load center	3	24 in (500 mm)	

## WEIGHTS

Service weight	4	unloaded	9,965 lb (4,520 kg)
Axle load	5	loaded/unloaded, front	14,079/3,582 lb (6,386/1,625 kg)
	6	loaded/unloaded, rear	2,500/6,382 lb (1,134/2,895 kg)

## TIRES

Tire type	7	Pneumatic	
Wheels	8	front/rear	2/2
Wheelbase	9	66.9 in (1,700mm)	
Tire size	10	front	28x9-15-14PR
	11	rear	6.5-10-10PR
Tread width	12	front/rear	39.4/39.1 in (1,000/992 mm)

## MAST

Max. fork height	13	with std 2-stage mast	118.1 in (3,000 mm)
Free lift	14	with std 2-stage mast	5.7 in (145 mm)
Height, upright lowered	15	with std 2-stage mast	87 in (2,210 mm)
Height, upright extended	16	with std 2-stage mast	159.3 in (4,046 mm)
Mast tilt, fwd, back	17	with std 2-stage mast	6°/12°
Carriage	18	ISO Class	III
		width	40.9 in (1,100 mm)
Fork spread	19	minimum	9/39.7 in (272 mm)
Fork dimensions	20	T x W x L	1.5 x 3.9 x 42 in (45 x 122 x 1070 mm)

## CHASSIS

Length to fork face	21	with std 2-stage mast	106 in (2,693mm)
Overall width	22	48.2 in (1,225 mm)	
Overhead guard height	23	86.6 in (2,200 mm)	
Turning radius	24	minimum outside	94.5 in (2,400 mm)
Fork overhang	25	with std 2-stage mast	19.6 in (498 mm)
Right angle stack	26	add load length and clearance	163.3 in (4,147 mm)
Ground clearance	27	minimum loaded	4.1 in (105 mm)
	28	center of wheelbase	6.5 in (165 mm)

## Performance

Model	CLG2030G-3		
Travel speed	29	loaded/unloaded	11.2/11.8 mph (18/19 km/h)
Lift speed	30	loaded/unloaded	104.3/110.2 fpm (.53/56 m/s)
Lower speed	31	loaded/unloaded	100.4/92.5 fpm (.51/.47 m/s)
Max. drawbar pull	32	loaded	3,858 lb (1,750 kg)
Max. gradeability	33	loaded/unloaded	20/31%

## Systems

Brakes	34	service	Foot/hyd
	35	parking	Hand/mech
Engine	36	manufacturer	Kubota
	37	model	WG2503-GL-E3
	38	emission compliance	EPA certified
	39	cylinders	4
	40	displacement	2.491 liter
	41	rated power	55.4 hp (41.3 KW)
	42	max. torque	128/1,600 lb/ft 1,200 rpm
Transmission	43	type	Powershift
	44	speeds, fwd/rev	1/1
Hydraulic Pressure	45	system	2,625 psi (181 bar)
	46	attachment	2,248 psi (111 bar)

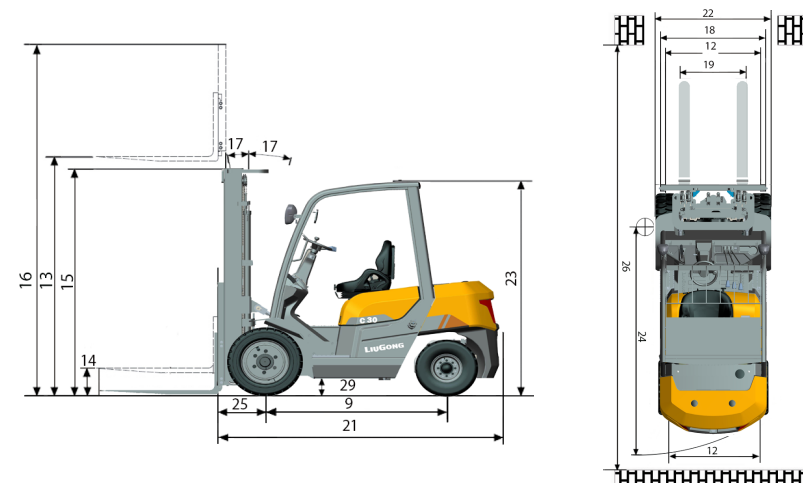

## LGNA-SS-2030G-3-202304-ENG-US

Specifications and designs are subject to change without notice. Machines shown may include optional equipment.

LiuGong Construction Machinery N.A., LLC.  
22220 Merchants Way - Suite 100  
Katy, TX 77449  
USA

T: 281-579-8882  
www.liugongna.com

F: 281-579-8388