

# 2035G-3

C-SERIES FORK TRUCK

ENGINE  
Kubota  
(LPG or Dual Fuel)

RATED POWER  
55.4 hp  
(41.3 KW)

CAPACITY  
6,000 LB  
(3,500 kg)



# SPECIFICATIONS

EXCLUSIVELY FOR DEALER

## GENERAL

Model		CLG2035G-3-3	CLG2035G-3
Power type	1	Gasoline/LPG	LPG
Operator type	2	Sit-Down Rider	
Base capacity	3	6,000 lb (3,500 kg)	
Load center	4	24 in (500 mm)	

## WEIGHTS

Service weight	5	unloaded	10,906 lb (4,947 kg)
Axle load	6	loaded/unloaded, front	15,692/3,424 lb (7,118/1,553 kg)
	7	loaded/unloaded, rear	2,930/7,482 lb (1,329/3,394 kg)

## TIRES

Tire type	8	Pneumatic	
Wheels	9	front/rear	2/2
Wheelbase	10	66.9 in (1,700mm)	
Tire size	11	front	28x9-15-14PR
	12	rear	6.5-10-10PR
Tread width	13	front/rear	39.4/39.1 in (1,000/992 mm)

## MAST

Max. fork height	14	with std 2-stage mast	118 in (3,000 mm)
Free lift	15	with std 2-stage mast	6 in (150 mm)
Height, upright lowered	16	with std 2-stage mast	87 in (2,210 mm)
Height, upright extended	17	with std 2-stage mast	159 in (4,046 mm)
Mast tilt, fwd, back	18	with std 2-stage mast	6°/12°
Carriage	19	ISO Class	III
		width	43.3 in (1,100 mm)
Fork spread	20	minimum/maximum	10.7/42.2 in (272/1,072 mm)
Fork dimensions	21	T x W x L	1.97 x 4.8 x 42.1 in (50 x 122 x 1070 mm)

## CHASSIS

Length to fork face	22	with std 2-stage mast	108.4 in (2,753 mm)
Overall width	23	48.2 in (1,225 mm)	
Overhead guard height	24	86.6 in (2,200 mm)	
Turning radius	25	minimum outside	95.9 in (2,435 mm)
Fork overhang	26	with std 2-stage mast	19.8 in (503 mm)
Right angle stack	27	add load length and clearance	165 in (4,192 mm)
Ground clearance	28	minimum loaded	4.1 in (105 mm)
	29	center of wheelbase	6.5 in (165 mm)

## Performance

Model		CLG2035G-3-3	CLG2035G-3
Travel speed	30	loaded/unloaded	11.2/11.8 mph (18/19 km/h)
Lift speed	31	loaded/unloaded	104.3/110.2 fpm (.53/.56 m/s)
Lower speed	32	loaded/unloaded	100.4/92.5 fpm (.51/.47 m/s)
Max. drawbar pull	33	loaded	3,858 lb (1,750 kg)
Max. gradeability	34	loaded/unloaded	18/22%

## Systems

Brakes	35	service	Foot/hyd
	36	parking	Hand/mech
Engine	37	manufacturer	Kubota
	38	model	WG2503-GL-E3
	39	emission compliance	EPA certified
	40	cylinders	4
	41	displacement	2.491 liter
	42	rated power	55.4 hp (41.3 kW)
	43	max. torque	129/1,600 lb/ft (175/1,200 N/m) 1,200 rpm
Transmission	44	type	Powershift
	45	speeds, fwd/rev	1/1
Hydraulic Pressure	46	system	3,046 psi (210 bar)
	47	attachment	2,248 psi (155 bar)

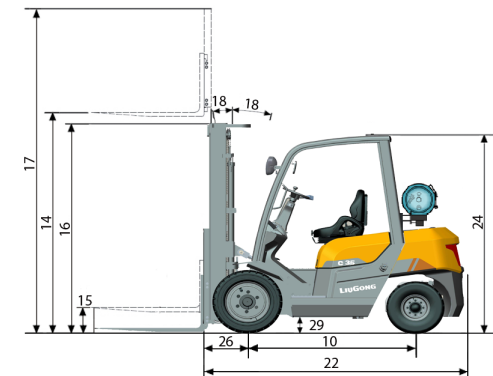
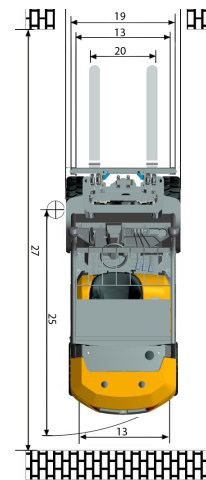

### LGNA-SS-2035G-3-202302-ENG-US

Specifications and designs are subject to change without notice. Machines shown may include optional equipment.

LiuGong Construction Machinery N.A., LLC.  
22220 Merchants Way - Suite 100  
Katy, TX 77449  
USA

T: 281-579-8882  
www.liugongna.com

F: 281-579-8388