

TD-25M CRAWLER DOZERS

TIER 4 FINAL



ENGINE	TD-25M (TIER 4 FINAL)
Make and model	Cummins X15
Emissions standard	Tier 4 Final
Displacement	912 in ³ (15 l)
Bore and stroke	5.39 x 6.65 in (137 x 169 mm)
Gross horsepower, SAE J1995	375 hp (280 kW)
Net horsepower, SAE J1349/ISO 9249 at the max. speed of hydraulic fan	370 hp (277 kW) 330 hp (246 kW)
Rated rpm	2000
Max. torque	1600 lb-ft (2169 Nm) @ 1200 rpm
Air cleaner	Cummins Filtration Direct Flow™, dry type, with dash-mounted electronic service indicator and turbo air pre-cleaner
Cold-starting aid	Ether start
Slope operation, max. angle	45°

COOLING	TD-25M
Type	Suction-type variable-speed fan, hydraulically driven with perforated engine side sheets and heavy duty louvered front grill
Engine coolant rating	-34°f (-37°C)

OPERATOR STATION	TD-25M
ROPS	ROPS (ISO 3471 - 2008)
FOPS	FOPS (ISO 3449 - 2005)



UNDERCARRIAGE

TD-25M (TIER 4 FINAL)

Type	Rigid
Suspension	Oscillation-type with equalizer bar and forward mounted pivot shafts
Tracks	Large deep-heat-treated, sealed and lubricated track links and through-hardened, sealed and lubricated rollers for maximum wear resistance
Track gauge	7 ft (2140 mm)
Track shoe width	22 in (560 mm)
Chain	Sealed and lubricated
Shoes, each side	39
Track rollers, each side	7
Track length on ground	10 ft 9 in (3270 mm)
Ground contact area	5673 in ² (3660 cm ²)
Ground pressure	14.3 psi (98.6 kPa)
Track pitch	9.86 in (250 mm)
Sprocket sements, each side	8

HYDRAULICS

TD-25M (TIER 4 FINAL)

Type	Close-center load sensing hydraulic system with variable-displacement multi-piston double pump
Pump displacement	50 + 37 gpm (190 + 140 l/min)
System relief pressure	Blade lift/tilt & ripper 18.0 MPa (2,610 psi)
Control	Blade electric control valve; single joystick lever with blade automatic control and pitch/dual tilt control buttons

ELECTRICAL

TD-25M (TIER 4 FINAL)

Voltage	24 V
Number of batteries	4
Battery capacity	1920 CCA
Alternator rating	105A
Lights	10 total; cab mounted (side: 2 LH & 2 RH and 2 rear), 2 front - lift cylinders mounted and 2 rear fuel and hydraulic tanks mounted



POWERTRAIN

TD-25M (TIER 4 FINAL)

Transmission	Single stage 415 mm (16 in) torque converter with a 2.45:1 stall ratio drives to transmission through a double universal joint. Modular, countershaft type power shift transmission, electro-hydraulic control. Preset travel speed and auto-downshift.		
Steering	Exclusive 2-speed geared steering module provides gradual turns while maintaining full power to both tracks plus conventional clutch-brake performance for tight or pivot turns. Coupled to 3-speed transmission, the 2-speed steering provides 6 speeds forward and 6 reverse. The left hand joystick controls transmission and steering drive for up and down shifting, steering, Hi/Lo selection and LH/RH gradual turn.		
Final drives	Double-reduction planetary type final drives mounted independently of track frames and dozer push arms for isolation from shock loads.		
Total ratio	25.5 to 1		
Maximum drawbar pull	178,498 lbf (794 kN)		
Travel speeds	Forward	Reverse	
1st	Low	1.9 mph (3.0 km/h)	2.3 mph (3.7 km/h)
	High	2.5 mph (4.0 km/h)	3.0 mph (4.8 km/h)
2nd	Low	3.2 mph (5.1 km/h)	3.8 mph (6.1 km/h)
	High	4.1 mph (6.6 km/h)	4.9 mph (7.9 km/h)
3rd	Low	5.0 mph (8.0 km/h)	6.0 mph (9.6 km/h)
	High	6.4 mph (10.3 km/h)	7.6 mph (12.3 km/h)
Brakes service	Spring applied hydraulically released multi-disc wet brakes. Foot pedal linkage control.		
Brakes parking	The steering brakes also act as service and parking brakes. Service brakes are locked automatically when the transmission safety lever is actuated or when the engine is cut off.		

SERVICEABILITY

TD-25M (TIER 4 FINAL)

Refill capacities	
Fuel tank	203 gal (770 l)
Cooling system	17.4 gal (66 l)
Engine oil	13 gal (49 l)
Transmission system	63 gal (240 l)
Final drive, each side	16.9 gal (64 l)
Hydraulic reservoir	34 gal (131 l)
Adblue	10 gal (38 l)



DIMENSIONS

TD-25M (TIER 4 FINAL)

Type	Rigid
A: Overall height - FOPS cab	12 ft 3 in (3743 mm)
A1: Overall height - beacon	12 ft 10 in (3910 mm)
A2: Overall height - end of exhaust pipe	12 ft 4 in (3759 mm)
B: Grouser height	3 in (76 mm)
C: Ground clearance	22.6 in (576 mm)
D: Overall length, base machine	16 ft 7 in (5070 mm)
E: Track length on ground	10 ft 4 in (3270 mm)
F: Width over track	8 ft 10 in (2700 mm)
G: Track gauge	7 ft (2140 mm)

TD-25M

Blade Type	Semi-U	Full-U	Angle	Coal
D1: Length with blade and drawbar	22 ft 7 in (6880 mm)	23 ft 5 in (7150 mm)	22 ft 7 in (6890 mm)	24 ft 8 in (7530 mm)
D2: Length with blade and 1-shank/ 3-shank ripper	29 ft 4 in/27 ft 6 in (8940 mm/8380 mm)	29 ft 4 in/27 ft 6 in (9210 mm/8650 mm)	29 ft 4 in/27 ft 6 in (8950 mm/8390 mm)	- /29 ft 8 in (- /9030 mm)
F1: Width over trunnions	10 ft 6 in (3210 mm)	10 ft 6 in (3210 mm)	10 ft 6 in (3210 mm)	10 ft 6 in (3210 mm)

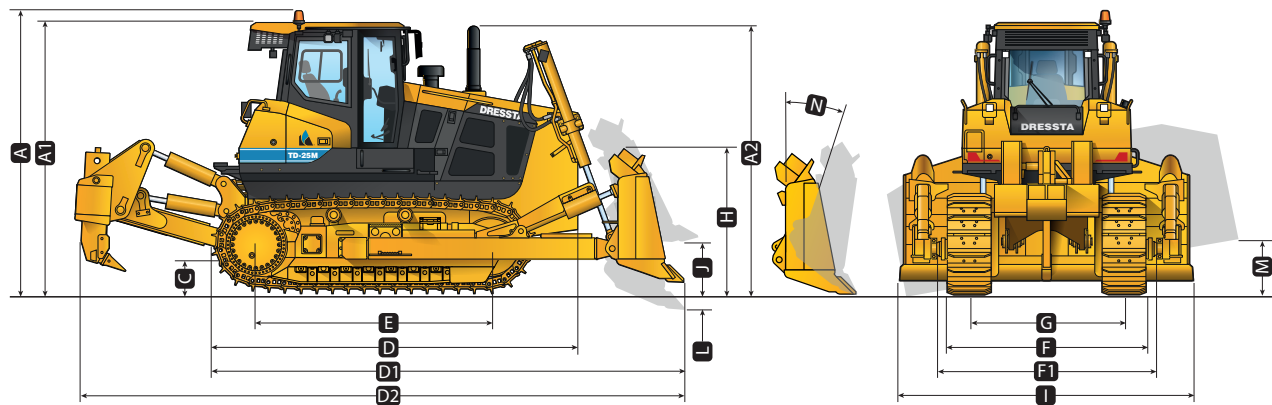

BLADE SPECS

TD-25M

Type	Semi-U	Full-U	Angle	Coal
SAE capacity	12.5 yd ³ (9.6 m ³)	15 yd ³ (11.5 m ³)	7.4 yd ³ (5.7 m ³)	27.5 yd ³ (21 m ³)
H: Blade height	5 ft 9 in (1760 mm)	5 ft 9 in (1760 mm)	4 ft 1 in (1260 mm)	6 ft 11 in (2100 mm)
I: Blade width	13 ft 3 in (4050 mm)	14 ft 3 in (4350 mm)	16 ft 3 in (4950 mm)	18 ft 5 in (5610 mm)
J: Blade lift height	4 ft 2 in (1270 mm)	4 ft 2 in (1270 mm)	4 ft 6 in (1370 mm)	4 ft 2 in (1270 mm)
K: Blade angle	-	-	25 deg	-
L: Blade digging depth	23.6 in (600 mm)	23.6 in (600 mm)	26 in (660 mm)	23.6 in (600 mm)
M: Maximum tilt	34.6 in (880 mm)	37.2 in (945 mm)	17.1 in (435 mm)	48 in (1220 mm)
N: Maximum blade pitch adjustment	10 deg	10 deg	-	10 deg
O: Overall width with blade angled	-	-	15 ft 1 in (4590 mm)	-



RIPPER

TD-25M

Type	Parallelogram ripper with hydraulic pitch adjustment		
	Standard	Deep	Multi-shank (3-shank)
R: Maximum clearance under tip (raised)	30.3 in (770 mm)	29.9 in (760 mm)	34.2 in (868 mm)
S: Overall beam width	57 in (1450 mm)	57 in (1450 mm)	98 in (2485 mm)
T: Slope angle (full raise)	30.8 deg	30.8 deg	30.8 deg
U: Ripping width	-	-	84 in (2134 mm)
V: Spacing center to center	-	-	42 in (1067 mm)
X: Maximum penetration	49.2 in (1250 mm)	66.9 in (1700 mm)	29.9 in (760 mm)
Z: Maximum pitch adjustment	25.1 deg	25.1 deg	25.1 deg
Penetration force	29768 lb (132.5 kN)	29768 lb (132.5 kN)	29494 lb (131.2 kN)
Pryout force	84907 lb (377.7 kN)	84907 lb (377.7 kN)	79467 lb (353.5 kN)
Shank positions (vertical)	4	6	2
Weight of ripper incl. shank(s)	11630 lb (5280 kg)	11840 lb (5370 kg)	11630 lb (5100 kg)
Weight of shank	-	-	700 lb (378 kg)

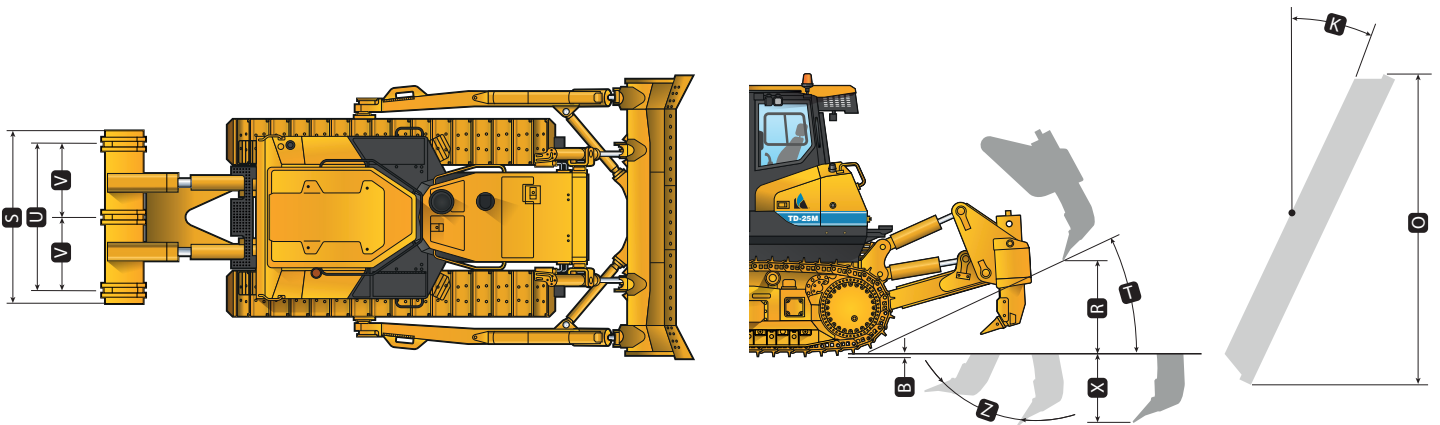

OPERATING WEIGHTS

TD-25M (TIER 4 FINAL)

Refill capacities	
Type	Rigid
Base weight with Semi-U blade w/tilt, single-shank ripper, standard equipment, cab ROPS/FOPS, full fuel tank, and 175 lb (79 kg) operator	90940 lb (41250 kg)
Optional components	
Ripper w/ 3 shanks	18784 lb (456 kg)
Track shoes	
24 in (610 mm)	+ 509 lb (231 kg)
26 in (660 mm)	+ 1074 lb (487 kg)
28 in (711 mm)	+ 1470 lb (667 kg)



STANDARD EQUIPMENT

ENGINE

TD-25M (Stage V)

- Engine, Cummins X15, Tier 4 Final, emission certified, turbocharged, with High Pressure Injection (HPI), Selective Catalytic Reduction (SCR), Electronic Controls (ECM), 277 kW (370 hp)
- Air cleaner, Cummins Filtration Direct Flow™, dry type with turbo air pre-cleaner and electronic service indicator
- Antifreeze, -34°F (-37°C)
- Cooling module; includes radiator, transmission oil cooler, hydraulic oil/fan drive oil cooler, fuel cooler, charge air cooler (CAC); isolation mounted
- Coolant filter conditioner
- Diesel Particulate Filter with catalyst (DPF) Exhaust resonator with elbow
- Fan, hydraulically driven, suction type, variable speed
- Filters, engine oil, full flow and by-pass with replaceable “spin-on” elements
- Fuel strainer
- Water separator, fuel system

DRIVETRAIN

- Torque converter, single stage
- Transmission, power shift, 3 speeds forward, 3 reverse, combined with 2 speed steering provides 6 speeds forward, 6 reverse, preset travel speed selection and auto-downshift
- Steering, planetary type, 2 speed, left hand single lever control (joystick)
- Filters, power train, equipment hydraulics, “spin-on” micro glass type
- Brakes, foot, spring applied, hydraulically released
- Decelerator - right foot pedal, and brake - center foot pedal

OPERATOR'S ENVIRONMENT

- Air conditioner/heater/pressurizer/defroster, behind roof mounted AM/FM radio with Bluetooth® and USB socket
- Cab ROPS/FOPS integrated (approved according to ROPS - EN ISO 3471 and FOPS - EN ISO 3449), sound suppression
- Tinted safety glass, dome light, 2 sliding side windows, 4 wipers with washers, heated rear glass, air recirculation system
- Mirrors, 1 piece interior, 2 pieces exterior
- Seat, air suspension type, fabric cover, adjustable, high back, fixed 15° to the right
- Arm rests
- Seat belt (EN ISO 6683) - 3" wide, retractable
- Sun visor for front cab window
- Fire extinguisher
- First aid kit

GUARDS

- Engine crankcase with pull hook and transmission guards, hinged
- Sprocket rock and dirt deflector
- Radiator guard, fan finger guard
- Engine hood, solid, sloped
- Engine side doors, hinged, perforated type
- Radiator guard doors, louvered, two-piece, hinged

HYDRAULIC CONTROLS

- Blade electric control valve (raising/lowering, LH/RH single tilt); single joystick lever with blade automatic control and pitch/dual tilt control buttons; 4-spool main valve w/ quick drop function; ready for ripper

INSTRUMENTATION

TD-25M (Stage V)

- Electronic Monitoring System, LCD display
- Normal and diagnostic operating modes for engine and drive train, hour meter, gear, range
- Gauges: voltmeter (battery charge), drive train oil temperature, fuel level, coolant temperature, tachometer (engine rpm), AdBlue® tank level
- Engine and drive train diagnostics program indicator lights
- Warning lights: engine ECM status, high drive train oil temperature, low coolant level, low engine oil pressure, high coolant temperature, low fuel level, high exhaust system temperature, AdBlue® tank low level, battery charge level, low transmission/clutch oil pressure
- Warning lights - air cleaner filter, exhaust system (SCR) filter, fan drive system filter, hydraulic oil filters, drive train pressure filter, seat belt fastening
- Audible alarm for low coolant level, low engine oil pressure, high coolant temperature
- Rear view camera
- Integrated rear view camera display
- Inclinometer (in both directions)

ELECTRICAL

- Alarm, back-up
- Alternator 105 A
- Batteries (4) 12 V, 1920 CCA, cold start, maintenance free rotating beacon light
- Horn, electric
- Lights on cab, cab side mounted - 2 LH & 2 RH; 2 rear, LED
- Lights with guards, 2 front - lift cylinders mounted, 2 rear - fuel tank & hydraulic tank mounted, LED
- Portable lamp receptacle, 12 V receptacle
- Starting/charging plug, 24 V starting

UNDERCARRIAGE

- Sprocket, segmented - 8 segments each side
- Track adjusters, hydraulic
- Track chain, sealed and lubricated (LTS) with split master link, 39 links (Stage V)
- Track chain guides, integral
- Track frame, 7 roller, 84 in (2 140 mm) gauge, oscillating type, lifespan lubricated rollers and idlers
- Track shoes, 22 in (560 mm), grouser type

OTHER STANDARD EQUIPMENT

- Cylinders, lift
- Diagnostic centers for power train and equipment hydraulic pressures
- Drawbar, fixed
- Ecological drains for engine oil, radiator coolant and hydraulic oil
- Manuals: parts and operator's
- Maintenance tool kit (includes grease gun)
- Shovel, fuel tank mounted
- Rear access platform
- Tools compartment
- Fuse set
- Vandalism protection, one key for all locks
- Emergency blade lowering



OPTIONAL EQUIPMENT

BLADE EQUIPMENT

D-2 Semi-U Dozer: 12.5 yd³ (9.6 m³), complete with all blade components, blade includes reinforced center push plate, with hydraulic tilt and manual pitch or hydraulic tilt/pitch

For coal application, spill guard on blade available

U-2 Full-U Dozer, 15 yd³ (11.5 m³), complete with all blade components, blade includes reinforced center push plate, with hydraulic tilt and manual pitch or hydraulic tilt/pitch

For coal application, spill guard on blade available

Coal Dozer, 27.5 yd³ (21.0 m³) for coal application, spill guard on blade available, complete with all blade components, blade includes reinforced center push plate, with hydraulic tilt and manual pitch or hydraulic tilt/pitch

G-2 Angle Dozer (manual angle), 7.4 yd³ (5.7 m³), complete with all blade components, with or without hydraulic tilt

REAR MOUNTED EQUIPMENT (STD & LT)(WT)

Drawbar, counterweight, 4100 lbs (1860 kg)

Additional counterweight (cast), 4410 lbs (2004 kg); recommended for use with large coal or landfill blades

Ripper, multi-shank with three shanks, partially mounted, with hydraulic pitch, includes deduct for drawbar, includes additional ripper light, LED, ripper frame mounted

Ripper single-shank beam, with hydraulic pitch, standard or deep dig, with electro-hydraulic pin puller and shank, partially mounted, includes deduct for drawbar, includes additional ripper light, LED, ripper frame mounted

TRACK SHOES (STD)

- 24 in (610 mm) shoes
- 26 in (660 mm) shoes, clipped corner
- 28 in (711 mm) shoes, clipped corner (not recommended for use with ripper)

OPERATOR'S ENVIRONMENT

For use with cab:

- Air recirculation system with MSHA filters, severe service
- Heated mirrors, 2 pcs, exterior
- Seat, heated, air suspension type, fabric cover, high back, adjustable (includes empty seat sensor and belt sensor)
- Sun visors (2), additional, for side door windows
- Additional cab lights, 2 front, LED
- Three-point seat belt (left or right)

SCREENS

- Sweeps, forestry, front and rear, for standard cab. Includes guard for fuel tank and hydraulic reservoir
- Screens for cab windows, (front, doors, side and rear) hinged, black painted
- Screens for cab lights (2 RH & 2 LH, 2 rear), black painted
- Screens for tractor lights (2 front, 2 rear)
- Screens for additional 2 front cab lights
- Screens for additional 2 lights on blade lift cylinders

GUARDS

- Final drive rock guard
- Radiator door screen for coal application
- Full length track roller guards
- Transmission and engine crankcase guards, severe service
- Electrical winch for engine crankcase guard
- Electrical winch for transmission guard
- Engine hood, perforated, sloped
- Fuel and hydraulic oil tank guard

ADDITIONAL OPTIONS

- Dressta Telematic system
- Emergency brake release system
- Ether start (only Stage V)
- Chrome exhaust pipe
- Fast fill fuel tank
- Inspection lamp, 12 V, portable, with 20 ft (6 m) cable
- Sound suppression package, for use with std solid or perforated hood
- Starting/charging receptacle plug assembly (required to jump start or charge batteries) with 15 ft cable
- 1000 h maintenance package (filters) 2000 h maintenance package (filters)
- Reversible fan
- Additional 2 lights on blade lift cylinders

EXPORT PACKING

- Export packing, drive-on/drive-off, machine on the trailer
- Export packing, drive-on/drive-off, machine on the railway wagon

FACTORY FIT OPTIONS

- Centralized Lubricating System, for machine with or without ripper

At Dressta we take pride in innovating to help our customers to achieve more in the jobs they do. Our dedicated team of application engineers can customize designs, modify standard equipment and adapt attachments for peak performance in specific application tasks, improving productivity and bottom line results.

Do you have a Special Feature Request? See how Dressta can help you achieve more in the jobs you do.